



MX1300XTS

Reprogrammable Hi-Power Blender with 64 oz. Stainless Steel Container



MAIN FEATURES

- Heavy-duty, high-performance 3½ peak HP motor with adjustable speed controls is the strongest in its class. It powers through the toughest ice and frozen fruit mixtures in seconds.
- Super-high 30,000 RPM motor speed for the smoothest consistencies.
- 4 reprogrammable beverage stations for perfect results every time.
 - Factory-set programs for the most popular beverage types
 - Easy to create your own customized programs – fully reprogrammable directly on the keyboard with no need for a USB or computer for programming
- Daily and total drink counter display.
- Variable speed and time selections for maximum control over consistencies.
- Dual PULSE feature with reprogrammable speed control.
- Easy-to-clean electronic-membrane keypad.
 - Premium, stainless steel container with 64 oz. capacity and cloverleaf jar design creates high-power vortex, funneling food directly into the blade. Unbreakable and dishwasher safe.
- Optional sound enclosure easily retrofits to base for noise reduction.
- High-performance, high-impact stainless steel blade is user replaceable for easy servicing.
- User-replaceable, metal-on-metal stainless steel coupling system for durability and reliability.
- Easily removable container cover with removable clear cap lets you add ingredients and reduce pressure during hot food blending.
- One-piece, dishwasher-safe, removable jar pad.
- Recommended for 75+ cycles per day.
- Limited Three-Year Motor and Two-Year Parts and Labor Warranty.

*Made in USA with US and foreign parts.

ELECTRICAL

Voltage: 230V

Frequency: 60Hz

Watts: 1560W

Amps: 12.5A

Plug Type: NEMA 5-15P

Cord Length: 6 feet



SALES FEATURES

Get smooth, consistent results every time with the Waring® MX1300XTS. This heavy-duty 3½ peak HP blender teams up with our stainless steel jar/ blade assembly for maximum power and efficiency. It's ferocious enough for everything from smoothies and frozen drinks to thick spreads, desserts, dressings, and all types of food preparation. The sturdy base features an easy-to-clean electronic-membrane keypad with blue backlit LCD screen and four reprogrammable beverage stations. Blend 75+ cycles per day.

Reprogrammable Hi-Power Blender with 64 oz. Stainless Steel Container

MX1300XTS



Reprogrammable Hi-Power Blender with 64 oz. Stainless Steel Container MX1300XTS

PARTS & ACCESSORIES

- | | | | |
|---|--|---|--|
|  | CAC90
64 oz. Stainless Steel Container |  | CAC95-12
64 oz. Green Copolyester Container |
|  | CAC93X
48 oz. Copolyester Container |  | CAC95-28
64 oz. Orange Copolyester Container |
|  | CAC93X-03
48 oz. Yellow Copolyester Container |  | CAC116
Blending Assembly Kit and Retainer Ring Kit |
|  | CAC93X-06
48 oz. Blue Copolyester Container |  | CAC119
Retainer Ring Wrench |
|  | CAC93X-10
48 oz. Purple Copolyester Container |  | CAC158
Blending Assembly Kit |
|  | CAC93X-12
48 oz. Green Copolyester Container |  | CAC159
Retainer Ring Kit |
|  | CAC93X-28
48 oz. Orange Copolyester Container |  | CAC182
Drive Coupling |
|  | CAC95
The Raptor® – Aggressive, All-Purpose, Stackable, 64 oz., BPA-Free Copolyester Container |  | CAC183
Drive Coupling with Square Drive |
|  | CAC95-03
64 oz. Yellow Copolyester Container |  | CAC169
Spatula – Custom designed for use with MX Series Blenders |
|  | CAC95-06
64 oz. Blue Copolyester Container |  | SE1500
Sound Enclosure |
|  | CAC95-10
64 oz. Purple Copolyester Container | | |

DIMENSIONS

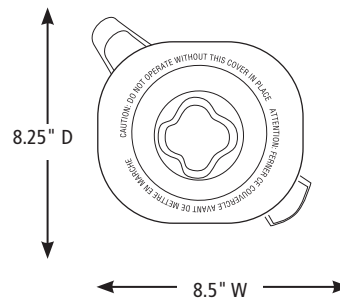
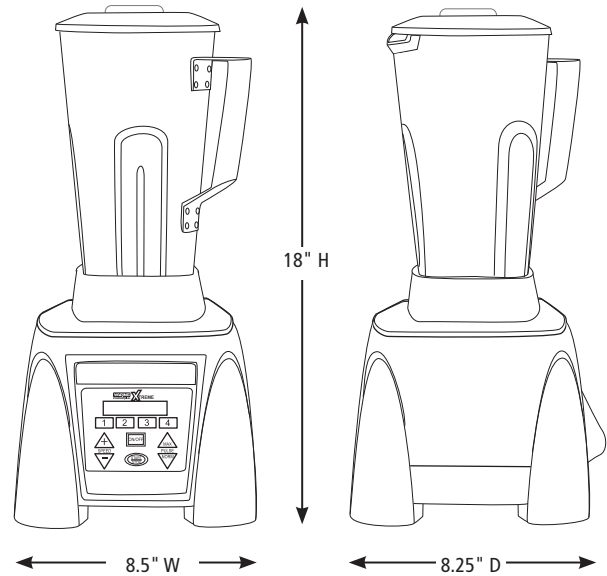

Out-of-Box Weight: 17 lb.

ORDERING INFORMATION	#STD. PKG.	GIFTBOX WEIGHT	CUBIC FEET	BOX DIMENSIONS D X W X H	UPC	CASE PKG.	MC WEIGHT	MC DIMENSIONS D X W X H	MBC
MX1300XTS– Reprogrammable Hi-Power Blender with 64 oz. Stainless Steel Container	1	18.15 lb.	1.037	11.375" x 10.250" x 15.375"	040072006852	1	19.1 lb.	11.875" x 10.875" x 16.375"	10040072006859



WolfLabs

Pricing on any accessories shown can be found by keying the part number into the search box on our website.

The specifications listed in this brochure are subject to change by the manufacturer and therefore cannot be guaranteed to be correct. If there are aspects of the specification that must be guaranteed, please provide these to our sales team so that details can be confirmed.

www.wolflabs.co.uk

Tel : 01759 301142

Fax : 01759 301143

sales@wolflabs.co.uk

Please contact us if this literature doesn't answer all your questions.